



Assembly, Installation, Operation and Maintenance Instructions

**2013 (only) Dodge 2500,  
4-Bolt Custom Bracket Kit**

**Part # 32084**

Use with 4 bolt base rail 31323 or 10 bolt 30686.

**Dealer / Installer:** Provide a copy of these Instructions to the end user of this product. These Instructions provide important operating and safety information for proper usage of this product. Demonstrate the proper use of the product with the end user. Have the end user demonstrate that they understand the proper use of the product.

**End User:** Read and follow all instructions included in this manual. Ask your Dealer / Installer for assistance if you do not understand the proper use of the product. Never remove any decals from the product.

**WARNING!** Never exceed the towing capacity of the tow vehicle. **Center Bolt Kit 32059 (sold separately) must be used when towing with a 26K hitch, Goose Neck, or Maneuvering System.**

**Torque 1/2" nuts to 75 lb-ft & 5/8" nuts to 150 lb-ft. Base Rails not included**

**CAUTION:** Do not install base rails over plastic bed liners. Plastic bed liners must be cut out of the way. Rails may be installed on spray in liners. Consult spray liner installer for recommended curing time.

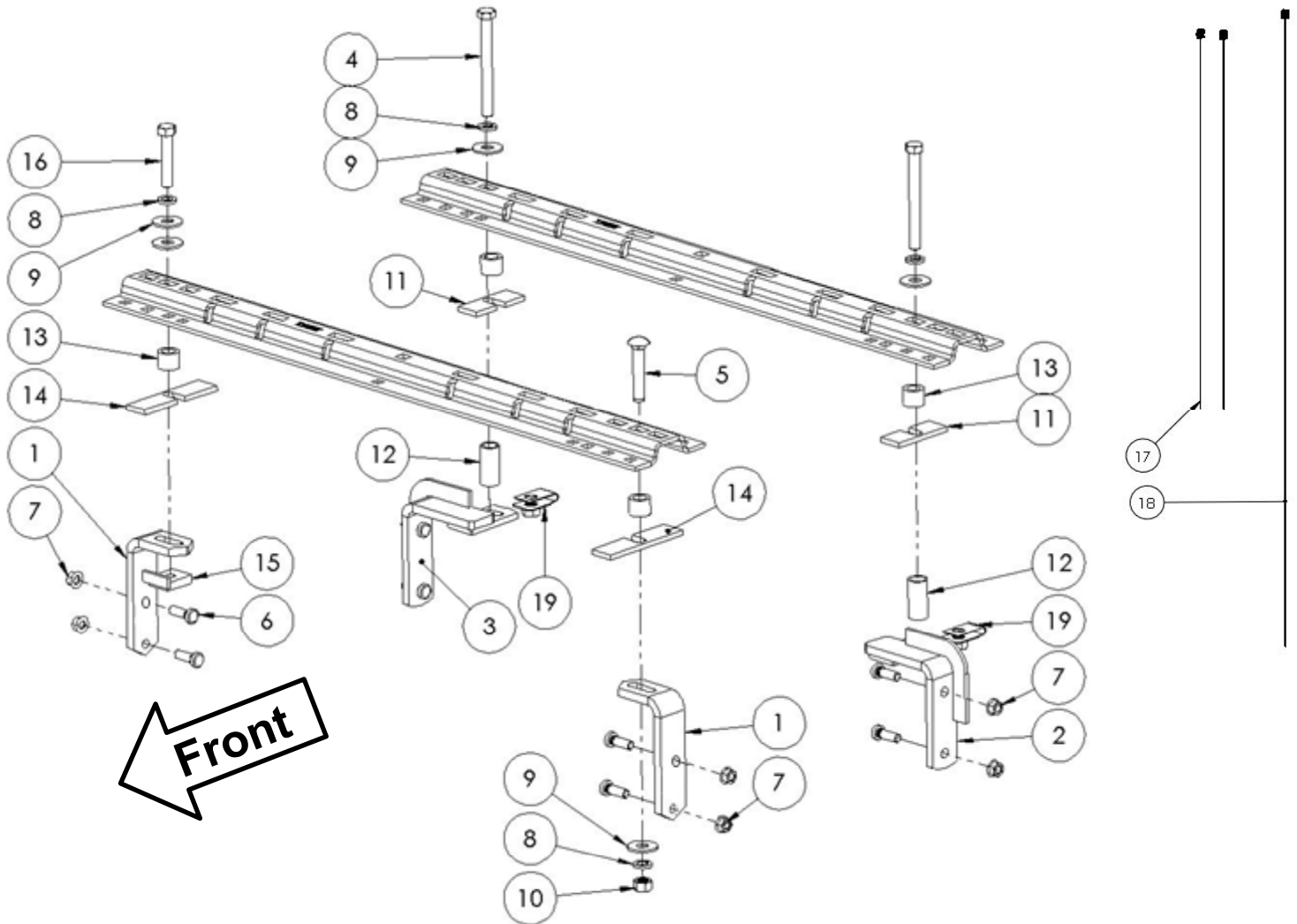

## TOOLS

3/16", 5/8", 17/32" drill bits.

1-1/4" hole saw

3/4" & 15/16" Socket & Open End

Wrench

Torque Wrench capable of 150 lb-ft.

1. The following instructions should be used to mount the fifth wheel. Care and attention to detail will ensure a quick quality installation. Check parts against parts list to become familiar with parts in kit.
2. Raise rear of truck high enough to allow jack stands to be placed under rear spring hanger bracket of truck. This will provide maximum room to install the fifth wheel brackets.

# WARNING

**If the truck is raised, be sure that the truck is properly blocked and restrained to prevent the truck from falling. Failure to do so may result in the truck suddenly falling, causing death or serious injury.**

3. Do not install mounting rails over plastic bed liners. Plastic bed liners must be cut out of the way. Base rails may be installed on dry/cured spray in liner. **Note: Consult installer for recommended curing time.**
4. Use only the supplied bolts, nuts, and washers to install this kit. All bolts are Grade 5 and nuts are Grade 5 unless specified otherwise.
5. Each frame bracket must be bolted to the vehicle frame with two bolts.



**These instructions are guidelines only. Actual installation is the responsibility of the installer and the owner. Always measure truck and trailer before installing hitch to be sure that there is clearance at the cab and at the bumper to allow for turns.**

6. Measurements are given from Rear Edge of truck bed to rear edge of the base rail closest to the Rear Edge of truck for most vehicle applications.
7. Center hitch between fender wells and make sure rails are square. Adjust position of rails until both diagonal measurements are the same. This should allow installation of a gooseneck or other fifth wheels to these rails.



**Check for obstructions before drilling. Failure to do so could result in damaged fuel or brake lines, structural members, etc. HUSKY TOWING PRODUCTS does its best to communicate tow vehicle manufacturer changes; however, it is ultimately the responsibility of the installer to prevent damage due to installation.**

## PARTS LIST

Item No.	Description	Qty.
1	BRACKET, "L" LONG	2
2	BRACKET, DS, REAR	1
3	BRACKET, PS, REAR	1
4	5/8-11 UNC X 6" CARRIAGE BOLT	2
5	5/8-11 UNC X 3.5" CARRIAGE BOLT	1
6	1/2-13 UNC X 1.5 WHEEL BOLT	8
7	LOCKNUT FLANGE SERRATED 1/2 -13	8
8	LOCKWASHER 5/8 ID	4
9	FLAT WASHER, 5/8" ID	5
10	NUT, HEX 5/8 -11	3
11	SHORT SPACER PLATE	2
12	SPACER TUBE, .875" ID X 2.313" LONG	2
13	SPACER, 1.25" OD X 1" TALL	4
14	LONG SPACER PLATE	2
15	PLATE, 5/8 -11 TAPPED	1
16	BOLT, HEX, 5/8-11 UNC X 3.25"	1
17	PULL WIRE, 1/2"	2
18	PULL WIRE, 1/2" LONG	1
19	CLIP NUT, 5/8"-11	2

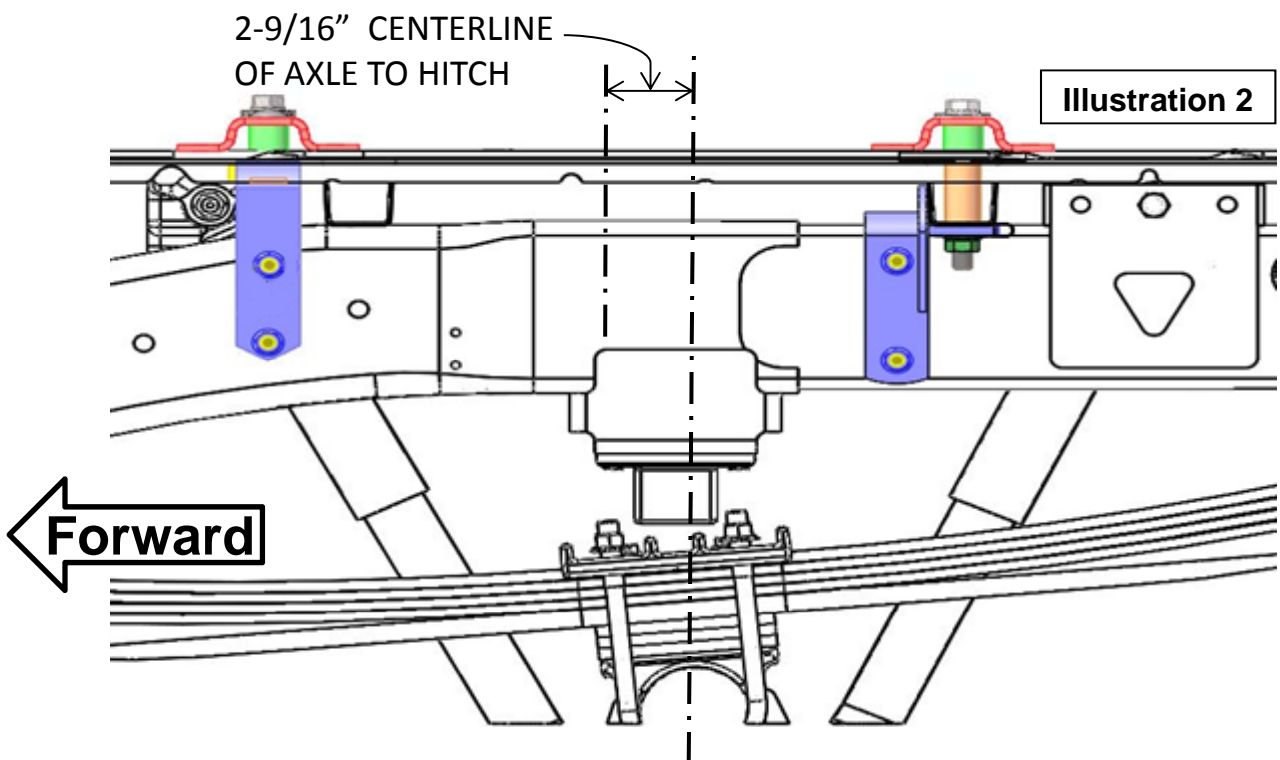
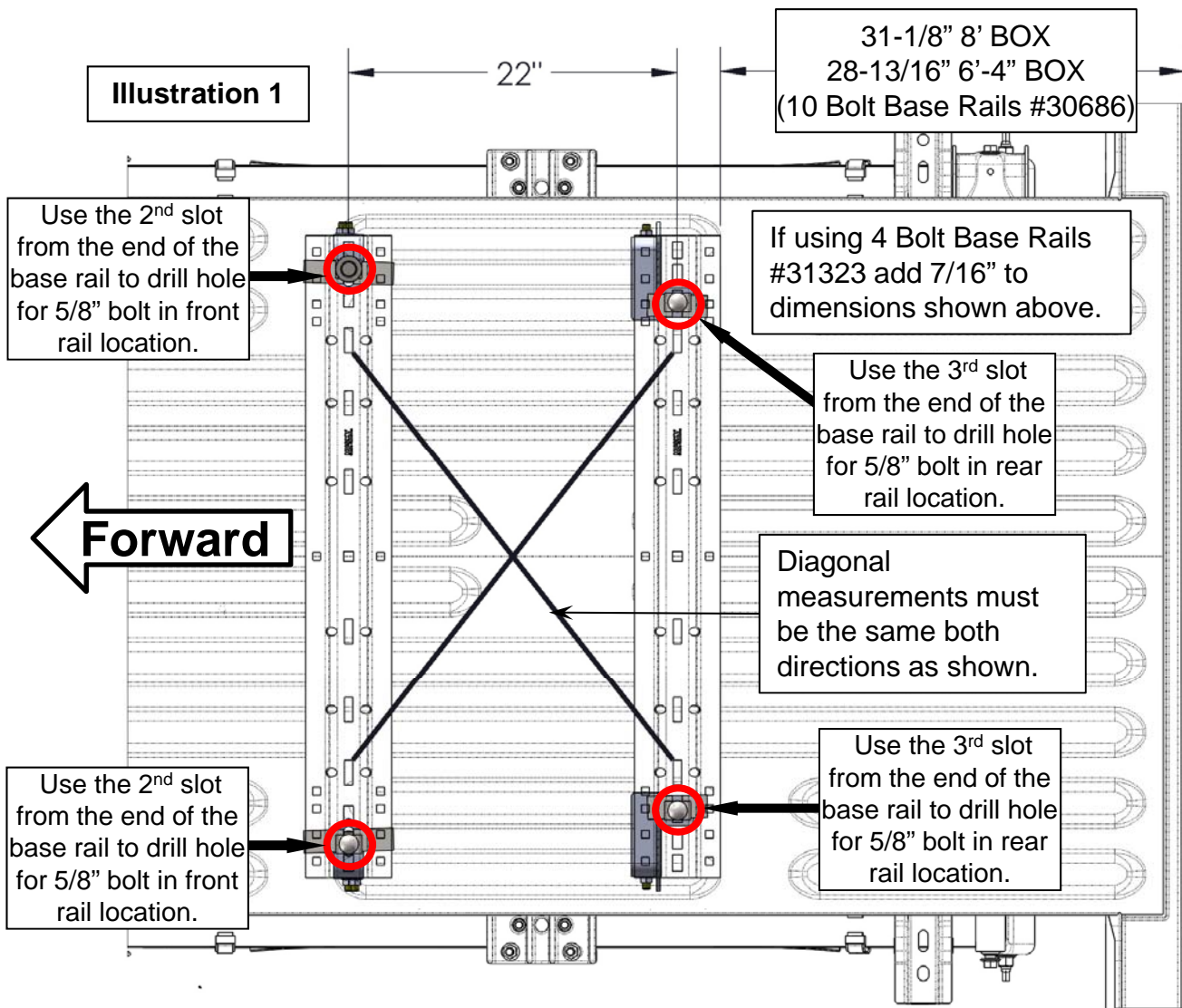

8. Place the two bed rails across the truck bed between the wheel wells. Position the 5th wheel uprights between the bed rails so that the tabs in the base of each upright will fit into the slots in the ends of the bed rails. Secure the uprights in place with the rail hitch pins and hair pins supplied with the 5<sup>th</sup> wheel installation kit. Securely attach 5th wheel cross member to uprights.
9. On most applications, the 5th wheel assembly should be positioned so that it is approximately centered over the truck axle and between the wheel wells on the bed floor.

**NOTE:** To keep the trailer from hitting the cab on tight turns there must be at least 52" between the hitch and the cab. On long bed pickups the hitch center line can be up to 3" ahead of the axle. On short bed pickups this position is not possible. A 5th wheel hitch that can move the trailer rearward away from the truck cab should be used with a pickup truck bed length less than 8 ft, consult the Husky Towing Products catalog to select the product that best matches your needs.

10. When hitch is correctly positioned in the bed and the bed rails are parallel, mark four attachment points on the truck bed using the 5/8" rectangular slots at the ends of each bed rail as noted in Illustration 1. Check below the bed before drilling holes to see that all wiring, brake lines or other obstructions are moved out of the way and will not be contacted by the drill.
11. Move the hitch assembly out of the way and drill four (4) 3/16" diameter pilot holes down through the bed at the previously marked points. Check under the bed where the (4) 3/16" pilot holes are and ensure that when the brackets are placed up against the frame they will line up.
12. Drill the forward 2 holes out to 5/8".
13. Drill the rearward 2 holes out to 1-1/4" going through the bed corrugation and any sheet metal directly under the bed but no farther! Using a 5/8" drill bit, continue drilling through the 1-1/4" holes through the bottom of the hat channels.
14. If the bed corrugation above the frame bracket is UP, leaving a space above the frame bracket, place a spacer plate (#11 or 14) in this location as shown in illus. 3A. If the corrugation is DOWN, at this location, place a spacer plate (#11 or 14) in the bed, under the base rail as shown in illus. 3B

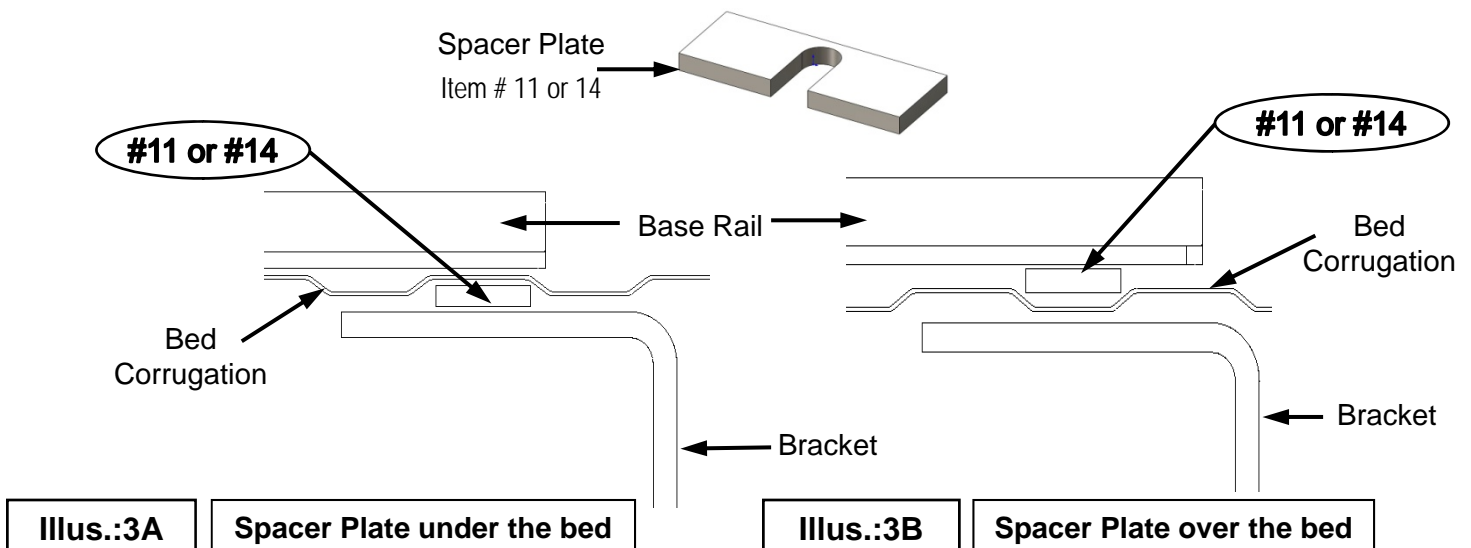



15. Insert (1) item #12 Spacer Tube in to each of the 1-1/4" holes under the base rail, short spacer plate item #11 will go under the bed corrugation on top of the tube spacer, replace base rail in position and then insert item #4 through #8, #9 into the 3<sup>rd</sup> slot from the outside. Hold bracket item #2 up to bottom of hat channel and install item # 19 and tighten finger tight only. Installation of #19 as shown in Illus.4B

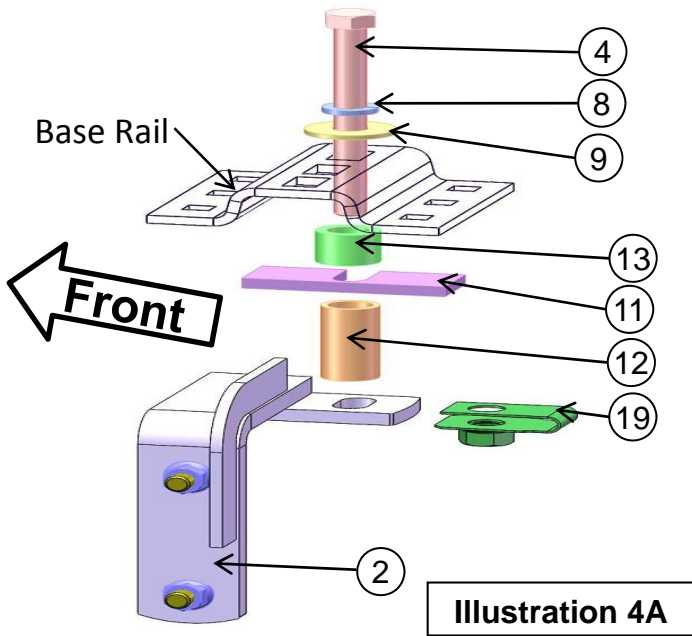

Driver Side Rear Shown

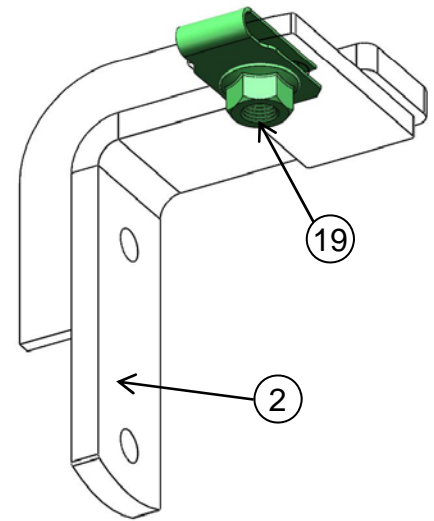

Illustration 4B

16. Each of the brackets must be attached to the side frame of the truck with two (2) special 1/2" wheel bolts #6. Drill two 3/16" pilot holes through the side of the truck frame using two of the holes in each angle bracket as guides then enlarge to 17/32" diameter. Use a clamp to hold bracket against the side of the frame while drilling holes.



Holes MUST be drilled 17/32" diameter, so that the special wheel bolts will seat properly. If holes are too small, the bolt may break. If hole is too large it will not grip properly. You can apply some grease to the splines only of the wheel bolts to ease the installation into the holes in the frame.

17. Use pull wire item #17 for rear brackets to guide wheel bolts through the inside of the frame and out through the drilled holes and brackets. Use the existing holes in the frame as indicated by balloon "A" see illustration 4C. Thread flanged hex nut item #7 on and tighten to 75 ft. lbs.

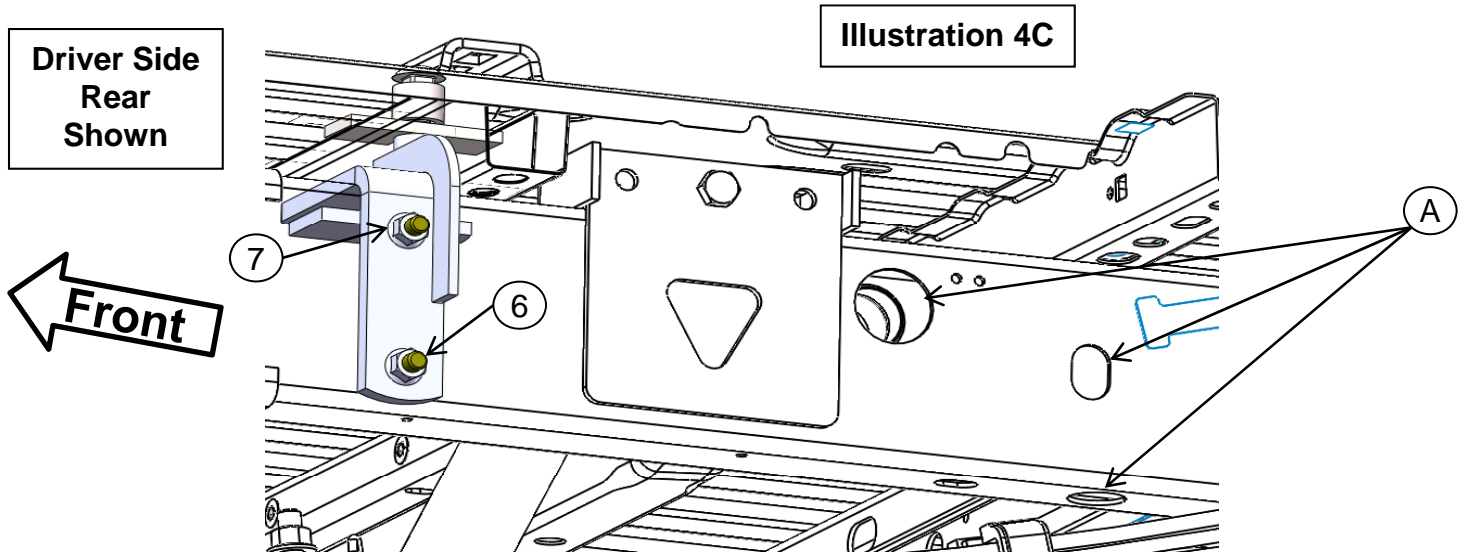

Driver Side Rear Shown

Illustration 4C

18. Follow steps 14 & 15 to mount Passenger side rear bracket.

19. Place (1) long spacer plate item #14 into the bed corrugation on top so the slot lines up with the hole drilled in the bed. Place (1) 7/8" thick spacer block item #13 on top of long spacer plate. Place forward base rail on top of spacers and guide 5/8" hex bolt item #16, (2) #9's, (1) #8 placed on bolt through middle slot in base rail, through spacer plates and the bed guiding it through the "L" bracket. Thread the tapped spacer plate item #15 onto the 5/8 bolt ensuring the rotation stop tab rests against the side of the "L" bracket. Only tighten hex bolt finger tight at this time. Installation of #15 as shown in Illus.5B

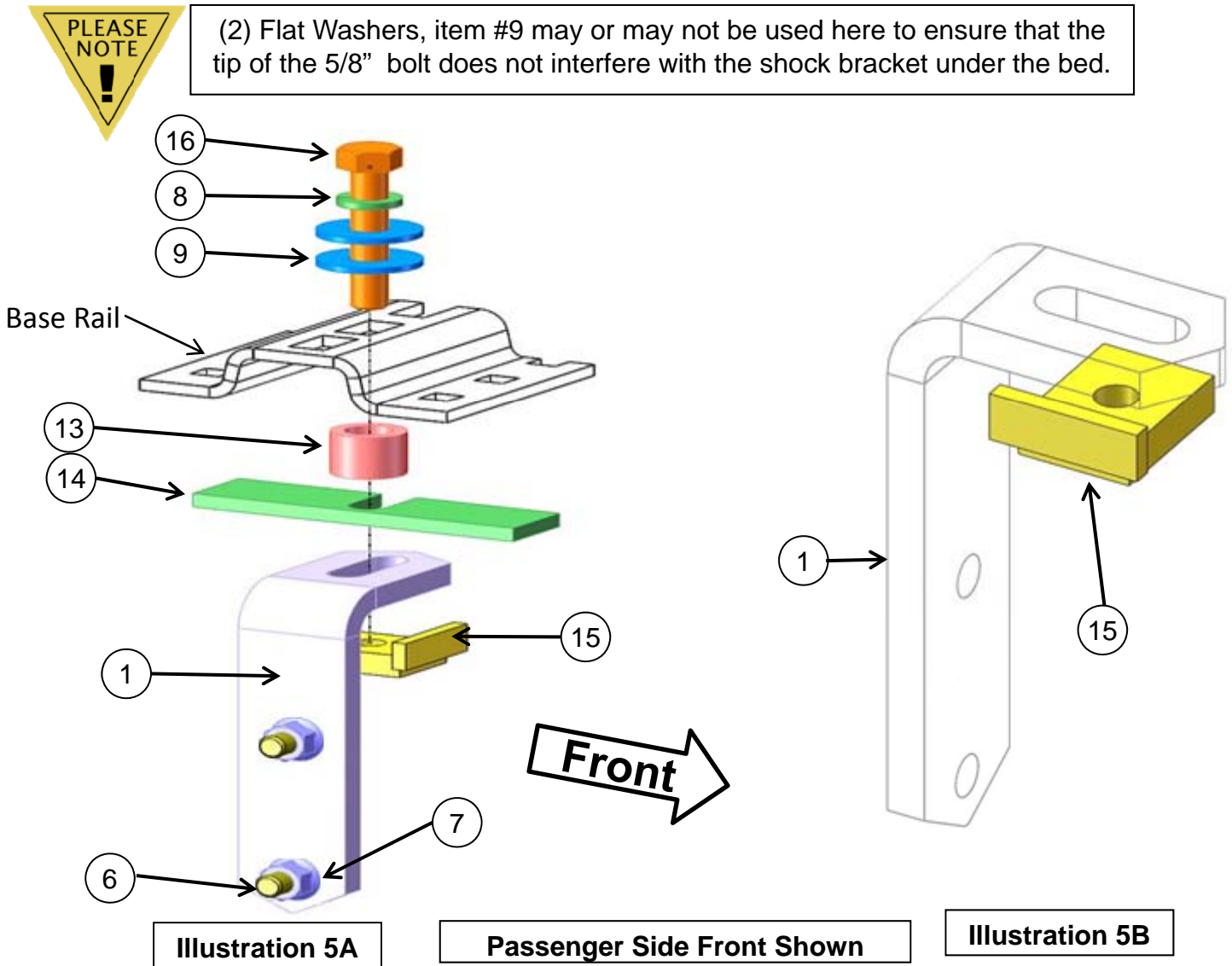

20. Each of the brackets must be attached to the side frame of the truck with two (2) special 1/2" wheel bolts #6. Drill two 3/16" pilot holes through the side of the truck frame using two of the holes in each angle bracket as guides then enlarge to 17/32" diameter. Use a clamp to hold bracket against the side of the frame while drilling holes.



Holes **MUST** be drilled 17/32" diameter, so that the special wheel bolts will seat properly. If holes are too small, the bolt may break. If hole is too large it will not grip properly. You can apply some grease to the splines only of the wheel bolts to ease the installation into the holes in the frame.

21. Use pull wire item #17 for rear brackets to guide wheel bolts through the inside of the frame and out through the drilled holes and brackets. Use the existing holes in the frame as indicated by balloon "B" see illustration 4C. Thread flanged hex nut item #7 on and tighten to 75 ft. lbs.

22. Place (1) long spacer plate item #14 into the bed corrugation on top so the slot lines up with the hole drilled in the bed. Place (1) 7/8" thick spacer block item #13 on top of long spacer plate. Place forward base rail on top of spacers and guide 5/8" carriage bolt item #5 through the middle slot in the base rail and then thread flat washer, lock washer and 5/8 hex nut finger tight only.

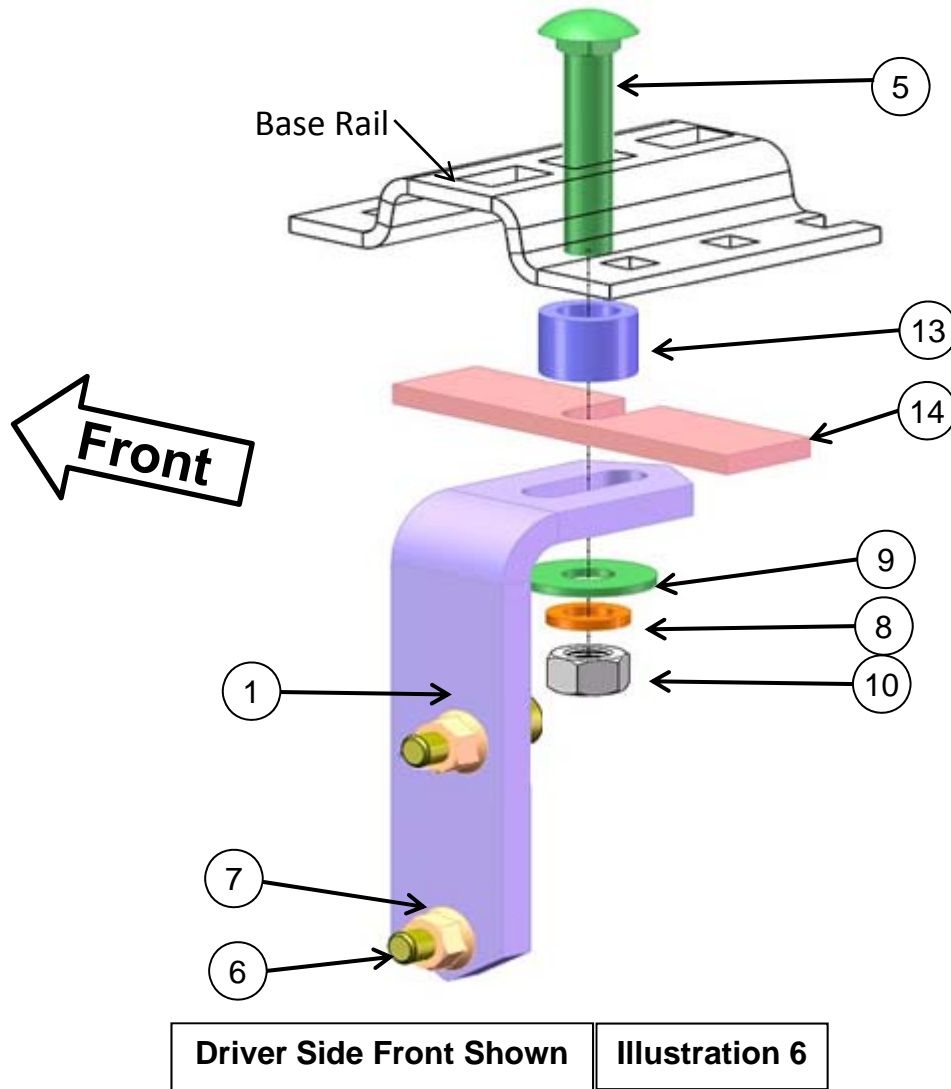

23. Each of the brackets must be attached to the side frame of the truck with two (2) special 1/2" wheel bolts #6. Drill two 3/16" pilot holes through the side of the truck frame using two of the holes in each angle bracket as guides then enlarge to 17/32" diameter. Use a clamp to hold bracket against the side of the frame while drilling holes.



Holes **MUST** be drilled 17/32" diameter, so that the special wheel bolts will seat properly. If holes are too small, the bolt may break. If hole is too large it will not grip properly. You can apply some grease to the splines only of the wheel bolts to ease the installation into the holes in the frame.

24. Use pull wire item #17 for rear brackets to guide wheel bolts through the inside of the frame and out through the drilled holes and brackets. Use the existing holes in the frame as indicated by balloon "A" see illustration 4C. Thread flanged hex nut item #7 on and tighten to 75 ft. lbs.
25. Go back and tighten the 5/8" nuts (#10) to 150 lb-ft torque. Tighten 5/8" bed rail attachment bolt (#4 & #16) to 150 ft-lbs. torque. Failure to tighten bolts as described may result in fastener loss or failure. **DO NOT** apply torque to the nut portion of the clip nuts (#19). You will **DAMAGE** it..

26. Check each rail hitch pin for freedom of movement in the bed rail connection. Adjust uprights, if necessary, by placing shim 31582 or 30243 between the upright and the cross member to obtain free pin movement. See Illus.7. Shims 31582 & 30243 sold separately.

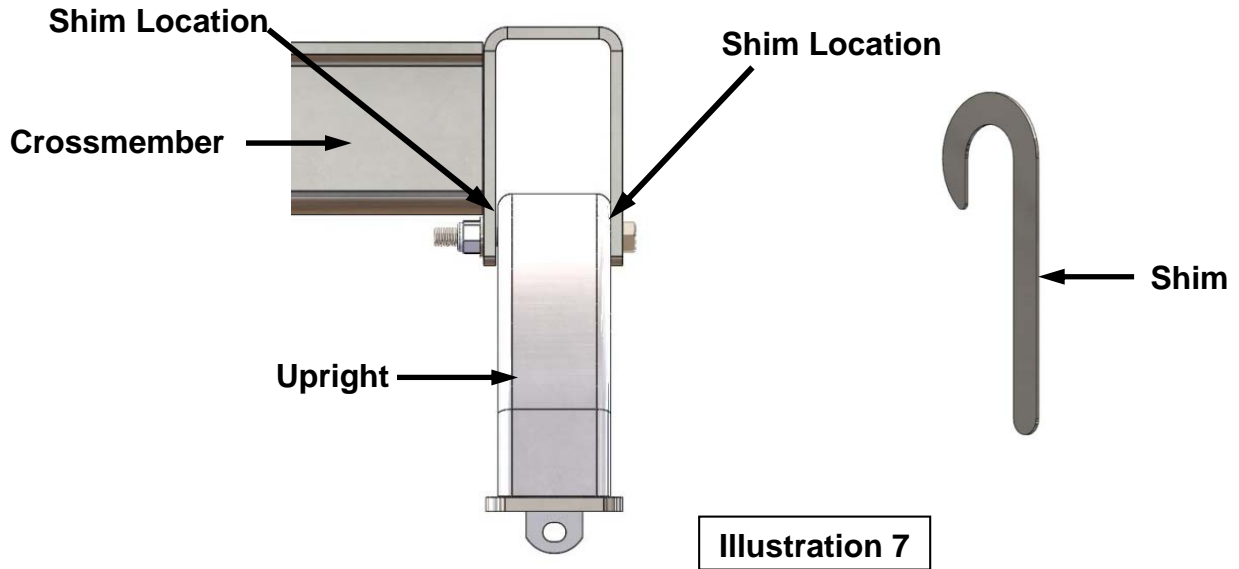



**#32084 CUSTOM BRACKET KIT,  
2013 ONLY, DODGE 2500**



WWW.HUSKYTOW.COM

Designed & tested in the USA & Made in China for /  
Conçu et testé aux É.-U. et fabriqué en Chine DTS  
Manufacturing, Wilsonville, OR 97070

P.O. #:

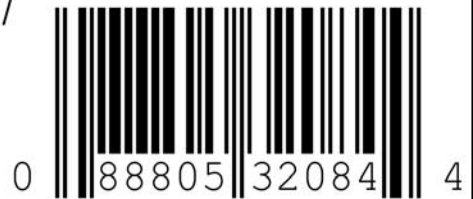

**The date code for this product is located on the UPC label**

**Please retain this info for your records.**

# Warranty Terms:

## 5 Year Limited Warranty:

This warranty applies solely to Husky 5<sup>th</sup> Wheel Installation Kit manufactured by DTS Mfg. for Husky Towing Products.

Husky Towing Products and DTS Mfg. make no guarantees or warranties for products not manufactured by DTS Mfg. Such products are covered solely under any applicable warranty of the manufacturer. It is always recommended that the operating instructions and guarantee instructions provided by the manufacturer are followed.

DTS Mfg. warrants its products to be free from manufacturing and material defects to the original purchaser for the length of warranty stated above from the date of retail purchase. If any products are found to have a manufacturing or material defect, the product will be replaced or repaired at the option of Husky Towing Products and DTS Mfg. with proof of purchase by the original purchaser. The original purchaser shall pay all transportation and shipping costs associated with the return of the defective product and the defective product shall become the property of DTS Mfg.

The Warranty applies to DTS Mfg. products used for individual and recreational purposes. Commercial usage of the DTS Mfg. products limits the warranty to 90-days from date of purchase.

The Warranty applies only to DTS Mfg. products which are found to be defective in manufacturing or material. This warranty does not apply to normal wear and tear of the finished placed on DTS Mfg. products.

Husky Towing Products and DTS Mfg. are not responsible for any labor costs incurred for removal or replacement of the defective product.

Husky Towing Products and DTS Mfg. are not responsible for repair or replacement of any product under the limited warranty where the product was improperly installed, misapplied, altered, abused, neglected, overloaded, misused or damaged as a result of an accident, including any use of the product not in accordance with all product operating and safety instructions.

Without limiting the generality of the foregoing, Husky Towing Products and DTS Mfg. shall under no circumstances be liable for any incidental or consequential loss or damage whatsoever arising out of, or in any way relating to any such breach of warranty or claimed defect in, or non-performance of the products. Some states do not allow the exclusion or limitation of incidental or consequential damages, so the above exclusion or limitation may not apply to you.

This limited warranty gives you specific legal rights, and you may also have other rights that vary from state to state.